

# Preparation of Cationic Polymer Surfaces by Grafting Polymerization

H. YASUDA\* and B. SHERRY, *Department of Chemical Engineering, University of Missouri-Rolla, Rolla, Missouri, 65401* and M.A. EL-NOKALY and S. E. FRIBERG, *Department of Chemistry, University of Missouri-Rolla, Rolla, Missouri 65401*

## Synopsis

A cationic polymer surface with extensive capacity for adsorption of anionic surfactants was prepared by graft polymerization of vinyl pyridine onto a plasma-treated polypropylene surface. The nitrogen was quaternized in order to obtain the cationic sites. The concentration dependence of adsorption from high electrolyte solution of the anionic surfactant was similar to the one on a solid surface from solutions with no added electrolyte. The hydrophobic contribution to the adsorption was experienced at surfactant concentrations far below its critical micellization.

## INTRODUCTION

Reverse osmosis is rapidly becoming an important method in the production of fresh water from seawater.<sup>1</sup> One of the more difficult problems for the process is the fouling of the membranes from colloidal matter in the seawater. This fouling leads to increased pressure drop and reduced productivity of the membrane and is one of the decisive factors for the shortening of the useful lifetime of a membrane.

We have found a potential solution to this problem in the form of a positively charged polymer filter; we expect the filter to be in reality a low-pressure drop pretreat adsorbent, an easily exchangeable cheap commodity.<sup>2</sup> During these investigations we found polypropylene surfaces onto which a quaternized poly(vinyl pyridine) had been grafted to have an extremely high adsorptive capacity for anionic surfactants from aqueous solutions in the concentration range of 1–100 ppm of the surfactant.

We found this phenomenon of sufficient novelty and interest to justify a publication on the specific grafting polymerization. To our knowledge grafting has not been described in the literature for a purpose of this kind although many different methods of grafting have been developed, including the joining of two preexisting polymers. The most common method, however, involves the following two steps:<sup>3</sup>



The asterisk implies an active site which may be either a free radical or a chemical group which may become involved in an ionic polymerization step or in a condensation process.<sup>4</sup> The activation step can be achieved by chemical

\* To whom correspondence should be addressed.

methods such as chain transfer or direct oxidation. Considerable research has also done on the use of high energy radiation which can directly form free radicals in the polymer without catalysis or pretreatment. One advantage of preirradiation methods is that they are very general, owing to the unselective adsorption of radiation in matter and can, in principle, be used to produce any desired combination of polymers.<sup>4</sup> The unselective absorption of radiation, however, could be a disadvantage when high concentrations of graft on the surface is needed.

More recently<sup>5-9</sup> glow discharges have been used to form free radicals on the surface only, without any swellings or degradation of the polymer. The use of a glow discharge for grafting purposes is a relatively new field. Most recent research in this area<sup>5-8</sup> is concerned with improving the surface properties of polymer fibers used in the textile industry. Glow discharge initiation of the surface has been carried out both in the presence<sup>7</sup> of the monomer and in its absence.<sup>8</sup>

Pavlat and Lee studied the graft polymerization of a number of nonvolatile monomers to wool.<sup>7</sup> Janca, Malcik, and Petrovsky studied the grafting of acrylic acid on materials (including polypropylene) initiated by glow discharge.<sup>8</sup> Eriksson, Gillberg, and Lagergren<sup>10</sup> described the implantation of cationic surfactants onto polymer surfaces as a technique for preparing positively charged surfaces suitable for the adsorption of heparin.

## EXPERIMENTAL

### Graft Copolymerization Method

#### *Apparatus*

The apparatus used is illustrated in Figure 1. It consisted of glass tubes with standard tapered joints. The reactor tube had an inner diameter of 40 mm and the discharge section was tapered from 50 mm to a 20 mm and inserted in the induction coil. The monomer and gas inlets were placed in the center of the discharge tube. The reactor tube was connected to a Hastings vacuum gauge and a differential pressure transducer (the M-S Baratron Pressure Gauge). The Hastings gauge was used to check the reference vacuum for the differential

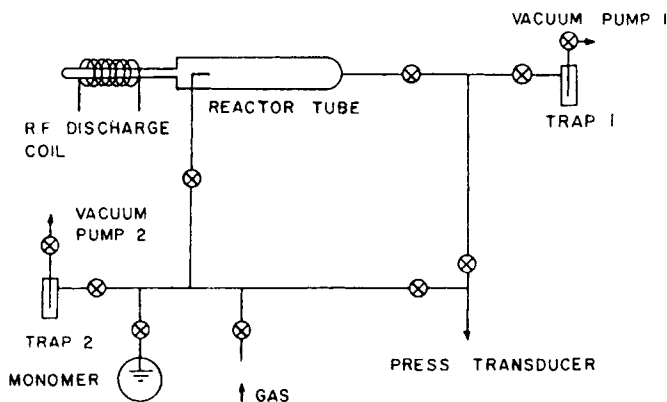

Fig. 1. Graft copolymerization apparatus.

pressure transducer ( $10^{-5}$  torr) and to calibrate the pressure gauge. The Hastings gauge cannot be used during glow discharge; hence, all glow discharge pressures were measured using the pressure transducer. The system can be pumped down to  $10^{-3}$  torr using the rotary pump number 1. A diffusion pump was used to keep the reference pressure at  $10^{-5}$  torr. The monomer was kept in the reservoir under vacuum connected to the apparatus by ground glass joints. The gas was fed in through a needle valve used to control the amount entering the reactor tube. This was measured by the pressure transducer.

The RF power supply was a radio-frequency transmitter, Tegal Model RFG 300. This operated at 13.56 MHz and delivered continuously variable output power from 0 to 300 W. A matching device, located between the generator coil and the supply, was used to match the impedance of the reactor tube and of the output. This was adjusted so that reflected power was kept at a minimum.

### *Procedure*

The monomer feed system was evacuated and checked for impurities using the cold finger (cooled by liquid nitrogen). The preweighed film sample was introduced to the reactor, and the system pumped down to  $10^{-3}$  torr using pump 1. The argon gas was introduced by controlling the opening of the needle valve while the downstream side of the apparatus was kept pumping. The pressure was measured using the differential pressure transducer. Once the desired gas pressure was reached and remained constant, the glow was initiated and set at the desired power level. The glow was maintained for a predetermined length of time and then turned off. The argon valve was closed and the system pumped down to  $10^{-3}$  torr using pump 1. The reactor tube was then isolated and the monomer valve opened fully. This enabled the monomer vapor to enter the reactor tube and equilibrate at its vapor pressure. This was left overnight to allow the vapor phase reaction between the monomer and the activated surface to take place. The monomer valve was then closed and the monomer vapor trapped using trap 1. This was also used to check for any air leakage that may have occurred during the vapor phase reaction. The trap was then isolated, removed, and the condensed monomer collected. Air was introduced into the system and the sample removed. The amount of grafting was determined by measuring the percent weight increase of the sample.

The grafted sample was then quarternized by immersing it in a dilute solution of hydrochloric acid under constant stirring for 1 h. It was washed many times in distilled water until the conductivity of a distilled water sample remained constant when the film was added. This ensured that most of the adsorbed monomer and homopolymers that were not grafted to the surface were removed.

Preliminary tests were conducted using both polypropylene and polyethylene film samples. The monomer used was 2-vinyl-pyridine. The amount of grafting was greater when polypropylene film was used as the substrate. In addition, the polyethylene film deformed slightly under the high temperatures generated by the glow discharge. Hence, polypropylene film was used throughout the grafting studies. The experimental conditions used in the graft reaction are illustrated in Table I.

TABLE I  
Graft Copolymerization Reaction Conditions

Polymer Film		Glow Conditions			Graft Conditions	
Area, cm <sup>2</sup>	Thickness, μm	Pressure, micron	Power, W	Duration, min	Monomer Type	Duration, h
150 ± 1.5	50	50 ± 1	80 ± 2	15 ± 0.1	Vinyl pyridine	12 ± 0.5

### Cationic Surfactant Implantation

The method used was that of Eriksson et al.<sup>10</sup>

#### *Apparatus*

A constant temperature water bath (Canen Instrument Co., Model M1) was used to keep the surfactant solution at a constant temperature. A built-in controller enabled the temperature to be controlled to within ±1°C. An ice bath was used to quench the samples.

#### *Procedure*

Cetyltrimethyl ammonium bromide (CTAB) was used as the cationic surfactant. Low-density polyethylene film was used as the substrate as its softening temperature (88°C–100°C) could be approached using water as a heating medium. Known CTAB solutions (ranging from 0.033 mM to 0.05M) were placed in the water bath and the bath heated to the desired temperature of 90°C–95°C. The polyethylene films were immersed in the surfactant solution and left for 5 h. The films were then removed, quenched by immersing in distilled water, placed in an ice bath, and washed in distilled water.

#### *Surface Property Measurements*

Wettability measurements were made by measuring advancing and receding distilled water contact angles using a goniometer (Rame Hart Inc., Model A-100). A microsyringe was used to place a 0.01 mL distilled water droplet on the sample surface and its contact angle was measured. Successive droplets of the same size were added at 1-min intervals and the advancing contact angle measured until the total drop volume was 0.09 mL. Then, using the same time intervals, 0.01 mL quantities of distilled water were successively removed and the receding contact angle measured until the drop size returned to 0.01 mL.

The surface morphology was determined using a scanning electron microscope.

## RESULTS

The nature of the surfaces produced by cationic surfactant implantation and by graft copolymerization was studied by determining their wetting characteristics.

### Cationic Surfactant Implantation

Figure 2 shows a plot of the advancing and receding contact angles as a function of the drop volume for an untreated polyethylene surface. Figure 3 is a similar plot after the surface had been implanted with cetyltrimethyl bromide (CTAB) under typical conditions used in this study. Similar results were obtained using a saline solution (containing 3.5% sodium chloride) as the wetting agent. Implantation with CTAB (0.03 mM–0.05M) solutions reduced only slightly the advancing contact angle of polyethylene. The receding contact angle, however, decreased as successive drops of water were removed.

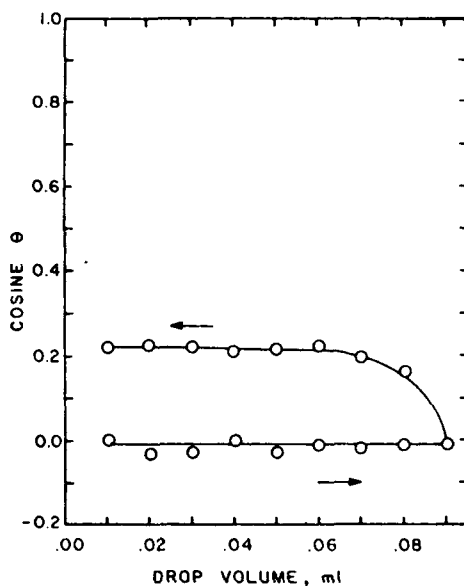

Fig. 2. Advancing and receding water contact angles of polyethylene.

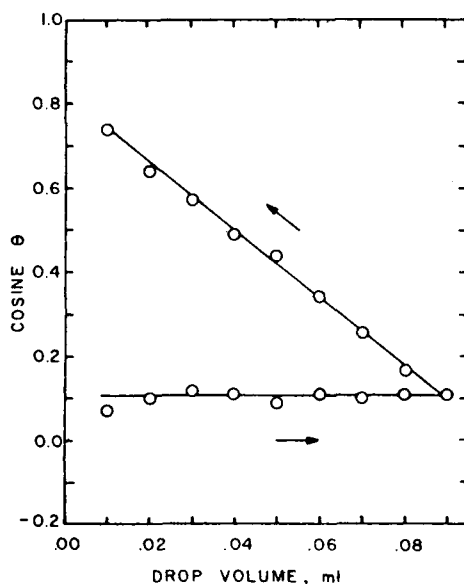

Fig. 3. Advancing and receding water contact angles of CTAB-implanted polyethylene.

The time dependence of the wetting measurements is shown in Figure 4 as a plot of the hysteresis effect against time between measurements of advancing and receding contact angles.

### Quarternized Graft Copolymer

The weight increase observed on grafting 2-vinyl-pyridine onto polypropylene varied from 10–15%. Following quarternization the weight decreased by less than 1%.

Advancing and receding water contact angle measurements for a typical grafted and quarternized sample are shown in Figure 5. The receding angle approaches zero.

The time dependence of the contact angle measurements presented in Figure 5 is shown in Figure 6 as a plot of hysteresis effect against time between measurements.

### Adsorption

For the adsorption studies, polyethylene films were implanted with CTAB from solutions of concentrations both above and below the critical micelle concentration. It was found that these films did not adsorb surfactant from solutions of initial bulk concentrations ranging from 5 to 100 ppm to an extent measurable by the analytical methods used.<sup>2</sup>

The positive surface, produced by grafting 2-vinyl-pyridine onto polypropylene film followed by quarternization in dilute hydrochloric acid, adsorbed a varying amount of from 20 to 81% anionic surfactant from solution. The amount adsorbed depends on both the concentration of the surfactant solution and whether

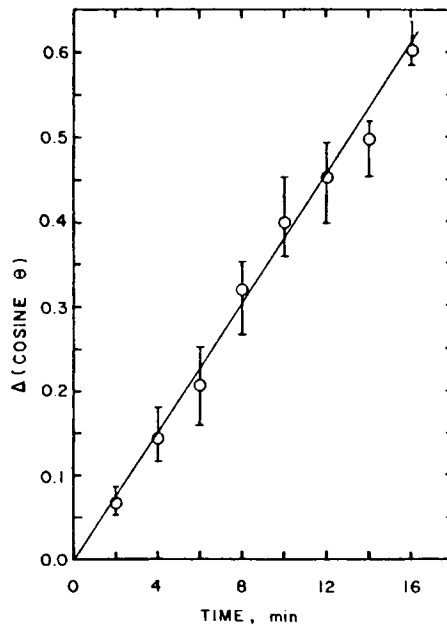

Fig. 4. Time dependence of hysteresis effect for CTAB-implanted polyethylene.

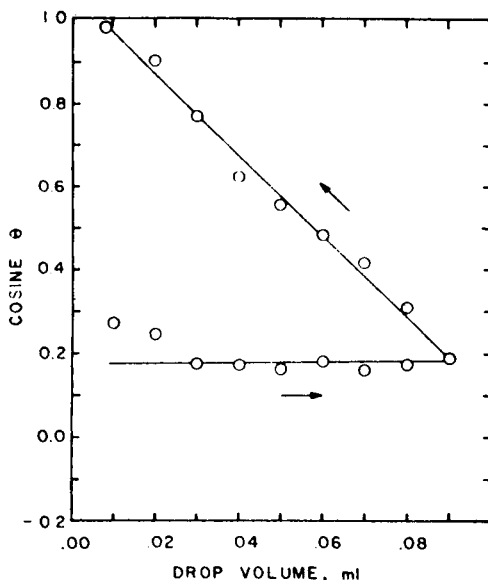

Fig. 5. Advancing and receding water contact angles of quaternized graft copolymer.

or not the solution contains sodium chloride, as seen in Figure 7 and discussed in ref. 2.

### DISCUSSION

Comparison between Figures 2 and 3 shows that implantation with CTAB only slightly reduced the advancing contact angle of polyethylene, indicating that the treated surface was still predominantly hydrophobic in contact with air.

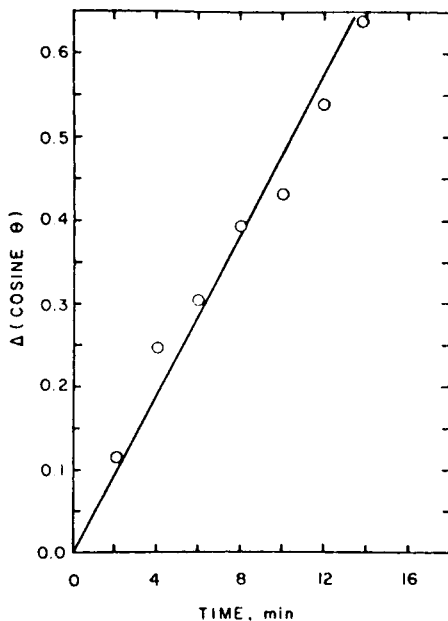

Fig. 6. Time dependence of hysteresis effect for quaternized graft copolymer.

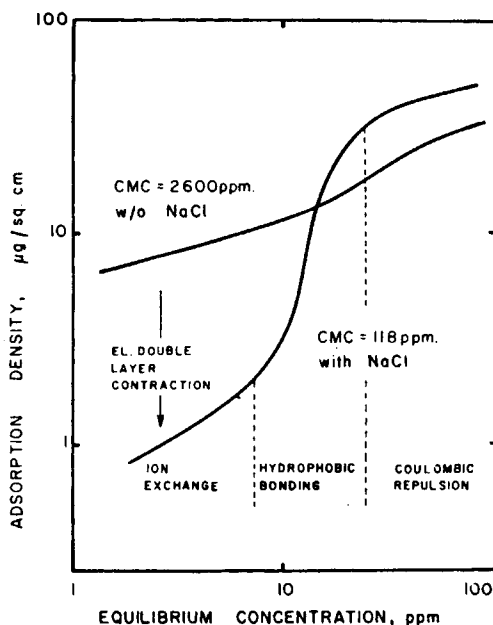

Fig. 7. Comparison of sodium lauryl sulfate adsorption from saline and nonsaline solutions.

However, implantation altered the receding contact angle measurements. These were not constant as in the case of the untreated surface, but decreased as water was removed.

These results add further evidence to the theory of surface mobility of molecules proposed by Yasuda, Sharma, and Yasuda<sup>11</sup> and Holley and Refujo.<sup>12</sup> Yasuda et al.<sup>11</sup> attributed the abnormally high degree of hysteresis (the difference between advancing and receding contact angles) observed in the contact angles of water for some polymer surfaces to the reorientation of hydrophilic groups of polymer molecules at the surface. It was proposed that the value of the water contact angle depended on whether hydrophilic moiety within the polymer molecule was oriented toward the air interface or toward the bulk of the solid but not on the hydrophilicity of the molecule.

In the present case, the hydrophobic chain end is implanted in the polyethylene surface leaving the hydrophilic group free to orient itself away from the air interface. According to Langmuir<sup>13</sup> a water drop on the surface tends to draw the hydrophilic groups to itself and to cause a reorientation of the molecules. Hence, the advancing edge of the contact angle is continually moving into a surface having few hydrophilic groups, while at the receding edge of the drop, the water must peel back from the surface on which there are many hydrophilic groups produced by the reorientation of the surfactant molecules (Fig. 8).

Hence, the present results are in agreement with results obtained as early as 1938 when Langmuir<sup>13</sup> observed that layers of stearic acid salts placed on surfaces with the hydrophilic groups facing outward gave advancing contact angle measurements practically identical to those obtained on the same films placed so the hydrophobic chains faced outward. He concluded that, as in the case above, on exposure to air the hydrophilic groups in the molecules were drawn below the actual surface.



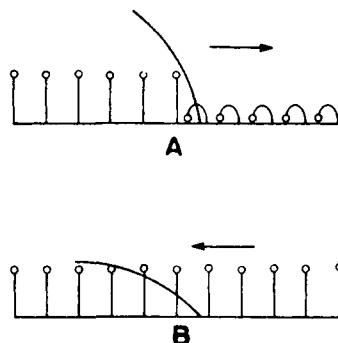

Fig. 8. Contact angle and surface mobility. A, advancing contact angle; B, receding contact angle.

Figure 4 shows that the hydrophilic nature of the implanted surfaces is strongly dependent on the time in contact with water. It also indicates, however, that the reorientation of the molecules takes place within minutes of immersion in water.

Quarternization should increase the weight of 2-vinyl-pyridine by 35%. Hence, if all the 2-vinyl-pyridine were grafted onto the polypropylene during the graft reaction, the overall copolymer weight should increase by 3–5%. The slight loss in weight, 1%, observed experimentally is due to the formation of a small amount of homopolymers which was removed by repeated washing in distilled water after the sample had been quarternized. The ratio of the amount of homopolymers formed to the amount of 2-vinyl-pyridine irreversibly grafted was in the region of 0.3–0.4. This indicates that a very high quality graft copolymer is obtained by activating the surface with a glow discharge. In many cases the activation of the surface using radiation techniques<sup>4</sup> can yield homopolymer-graft copolymer ratios exceeding unity. The overall weight increase obtained was greater than that obtained by Pavlath and Lee<sup>7</sup> using preimpregnation from aqueous or organic solutions. This is probably due to the considerable time allowed for vapor phase reaction to take place. It was observed that any leakage of air during the vapor phase reaction had a serious detrimental effect on the amount of monomer grafted onto the polypropylene surface.

The wettability behavior of grafted and quarternized sample (Fig. 7) is similar to that of the CTAB-implanted polyethylene surfaces. In this case, however, the receding angle approaches zero, indicating that the surface becomes completely hydrophilic when in contact with water. Hence, the quarternization of grafted 2-vinyl-pyridine on polypropylene appears to produce a much greater concentration of hydrophilic groups than implantation with CTAB molecules. Comparison between time dependence of hysteresis effect for CTAB implanted polyethylene (Fig. 4) and quarternized graft copolymer shows that the slope, hence the time dependence, is greater in the case of the grafted copolymer. The time scale within which both surfaces regain their hydrophilic character, however, is the same, indicating that quarternized graft copolymer has more hydrophilic moieties but the process involved in the rotation of hydrophobic moieties is essentially the same in both cases. This is in accordance with the postulation that the hydrophilicity is gained mainly by the short-range mobility, such as rotation along the axis of long chain molecules, rather than the long-range mobility, such as rearrangement of long chain molecules.<sup>11</sup>

### References

1. S. Sourirajan, Ed., *Reverse Osmosis and Synthetic Membranes, Theory, Technology, Engineering*, NRCC No. 15627, Ottawa, Canada 1977.
2. B. G. Sherry, H. K. Yasuda, M. A. El-Nokaly, and S. E. Friberg, to be published.
3. U. Stannett and T. Memetea, *J. Polym. Sci. Polym. Symp.*, **64**, 57 (1978).
4. A. Chapiro, *Radiation Chemistry of Polymeric Systems*, John Wiley, New York, 1962.
5. R. E. Belin, B. C. Fleischfresser, and T. A. Goh, *J. Text. Inst.*, **64**, 48 (1972).
6. M. M. Millard, S. I. Lea, and A. E. Pavlath, *Text. Res. J.*, **42**, 307 (1972).
7. A. E. Pavlath and K. S. Lee, *J. Macromol. Sci. Chem.*, **A10**(3), 630 (1975).
8. J. Janca, P. Malcik, and J. Petrovsky, *Folia. Fac. Sci. Natl. Univ. Parkyrianae Brun.*, **18**(3), 77 (1977).
9. A. E. Pavlath and R. F. Slater, *Appl. Polym. Symp.*, **19**(11), 1317 (1971).
10. J. C. Eriksson, G. Gillberg, and H. Lagergren, *J. Biomed. Mater. Res.*, **1**, 301 (1967).
11. H. Yasuda, A. K. Sharma, and T. Yasuda, *J. Polym. Sci. Phys.* **19**, 1285 (1981).
12. F. J. Holley and M. F. Refujo, *J. Biomed. Mater. Res.*, **9**, 315 (1975).
13. I. Langmuir, *Science*, **87**, 493 (1938).

Received September 23, 1981

Accepted November 10, 1981